



CLARK PACIFIC

1980 SOUTH RIVER ROAD TEL: (916) 371-0305
W SACRAMENTO, CA 95691 FAX: (916) 372-0323

13592 SLOVER AVENUE TEL: (909) 823-1433
FONTANA, CA 92337 FAX: (909) 823-1361

PROJECT

CONTRACTOR

JOB

SHEET **PCS-SK3**

DATE **3/15/07**

BY TA CHECK DW

TYPICAL REVEAL DETAIL

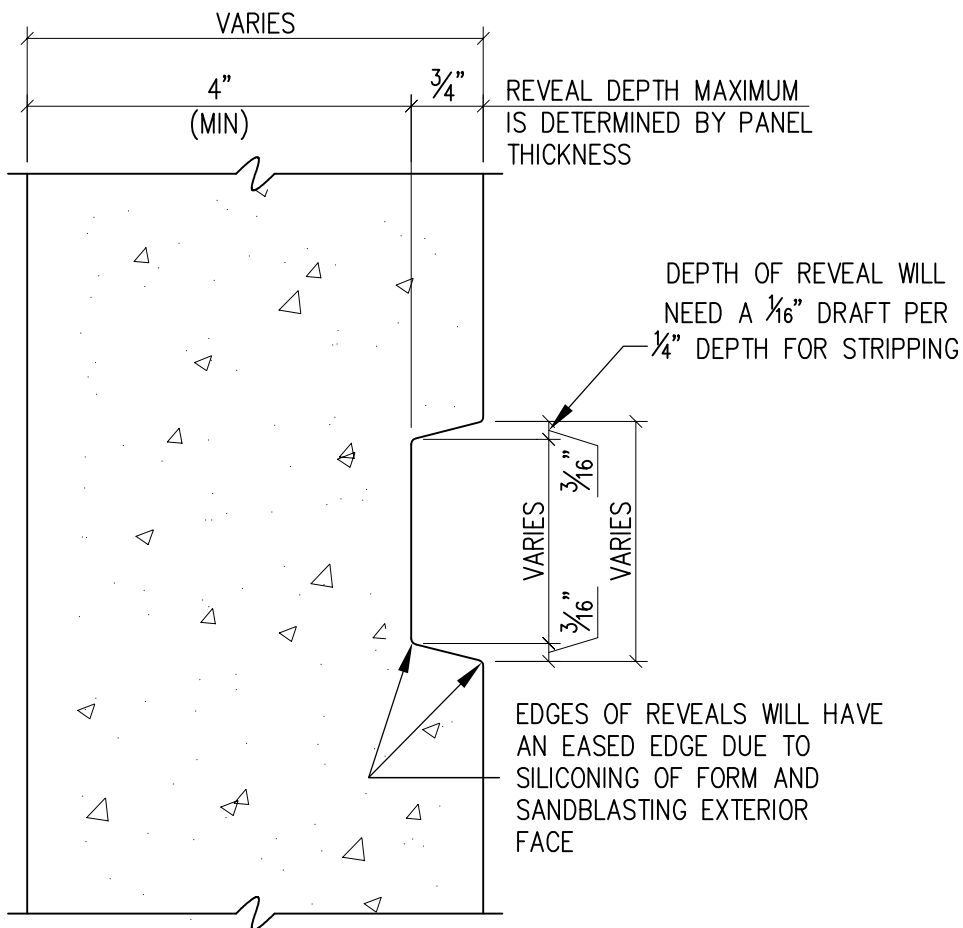

TYPICAL REVEAL DETAIL

SCALE: FULL

(PRECAST)